

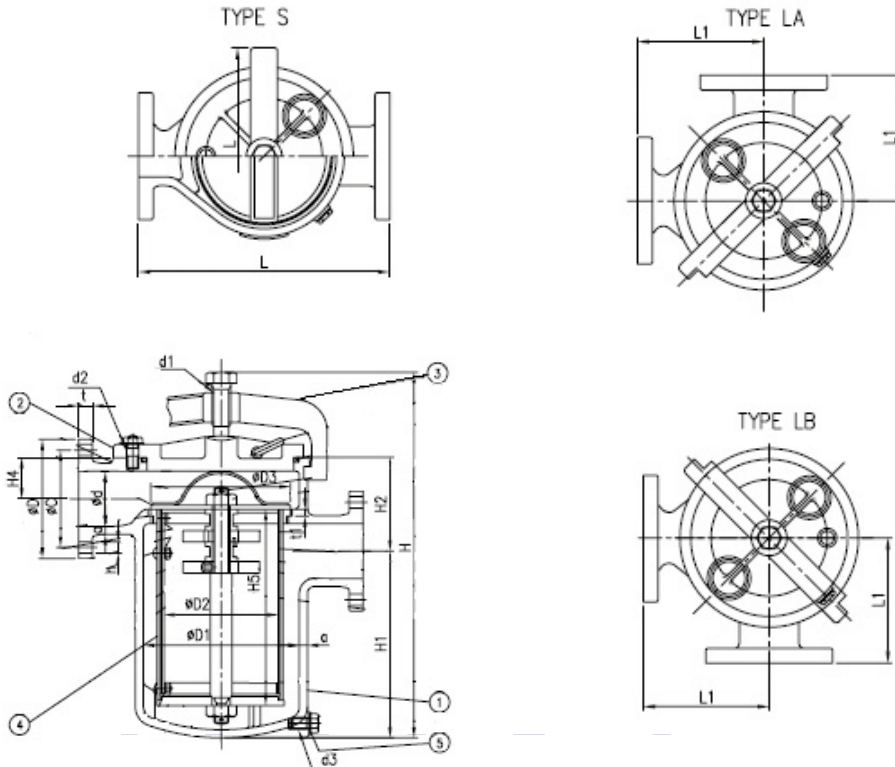

MARINE CAST IRON SIMPLEX OIL STRAINER - JIS F7209 (2) (dia. 50A to 100A)



No.	Component	Material
1	Body	FC200
2	Cover	FC200
3	Yoke	SS41 or FCD45
4	Filter cylinder	SS41
5	Magnet	Magnet steel

Nominal dia.	Test Pressure Mpa[kgf/cm ²]
25A to 300A	0.74 [7.5]

Type of fluid	Fluid temperature	MAX working Pressure Mpa[kgf/cm ²]
Fuel oil	60°C or less	0.49 [5]
Lubricating oil	80°C or less	

Size	d	L	L1	Flange					H	Body				Filter cylinder			kg
				D	C	No.	h	t		D1	H1	H2	H4	D2	D3	H5	
50A	50	280	140	130	105	4	15	16	395	160	187	92	42	125	150	190	25.8
65A	65	340	170	155	130	4	15	18	495	200	248	118	51	160	185	246	43.6
80A	80	370	185	180	145	4	19	18	525	230	258	132	59	180	210	276	51.0
100A	100	420	210	200	165	8	19	20	630	265	315	160	70	210	240	326	80.0